

## FITTING INSTRUCTION

Clamp mark in acc. with		Cables joining
ISO	PN	
1	L	Left directional lights
2	+	Rear fog lights
3	31	Ground
4	R	Right directional lights
5	58R	Right side parking lights
6	54	Stoplights
7	58L	Left side parking lights

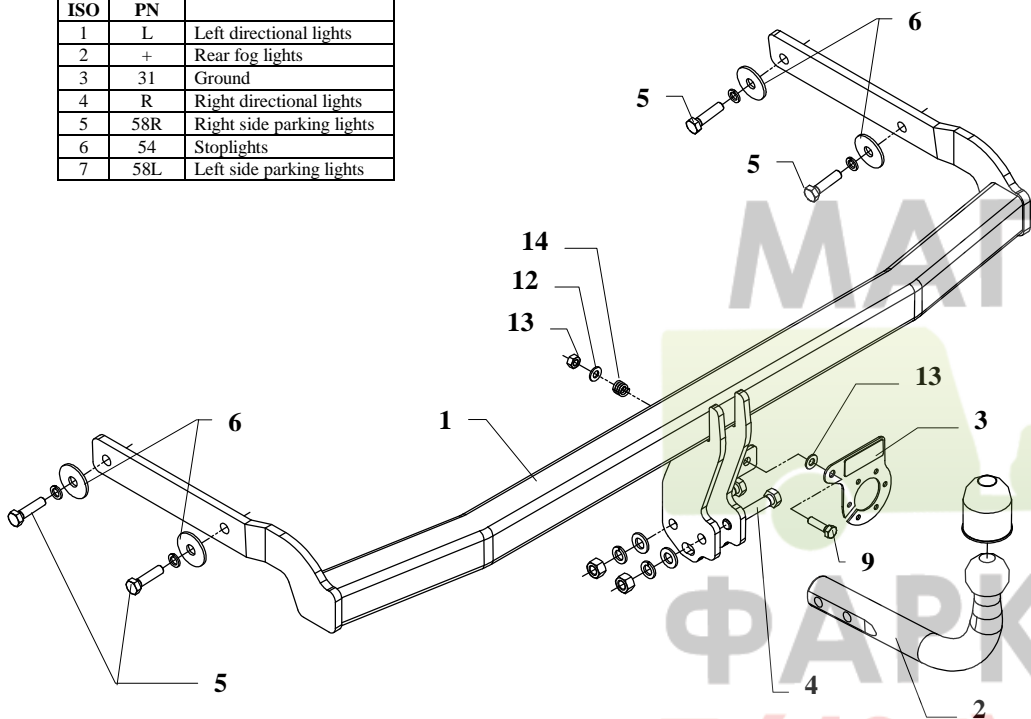

This towbar is designed to assembly in following car: **RENAULT MEGANE ESTATE**, produced since 07.2003 till 2009, catalogue no. **G46** and is prepared to tow trailers max total weight **1350 kg** and max vertical load **75 kg**.

### From manufacturer

Thank you for buying our product. Their reliability has been confirmed in many tests. Reliability of towbar depends also on correct assembly and correct exploitation. For this reasons we kindly ask to read carefully this instruction and apply to hints.

*The towbar should be install in points described by a car producer.*

## The instruction of the assembly

1. Disassemble a rear bumper and metal reinforcement (reinforcement not used any more).
2. Slip main bar of towbar (pos. 1) to chassis members, next screw using bolts M10x40mm (pos. 5) from accessories, use big, flat washers (pos. 6).
3. Reassemble bumper. **NOTE!** In some models possible necessity to make little undercut in lower edge of bumper.
4. Fix tow-ball (pos. 2) using bolts M12x70mm (pos. 4) from accessories.
5. Fix the socket plate (pos. 3) as shown on the drawing.
6. Tighten all bolts according to the torque shown in the table.
7. Connect electric wires of 7-pole socket according to the instruction of the car. (Recommend to make at authorized service station)
8. Complete paint layer damaged during installation.

Torque settings for nuts and bolts (8,8):

<b>M6</b> - 11 Nm	<b>M8</b> - 25 Nm	<b>M10</b> - 50 Nm
<b>M12</b> - 87 Nm	<b>M14</b> - 138 Nm	<b>M16</b> - 210 Nm





### NOTE

After install the towbar you should get adequate note in registration book (at authorised service station).The car should be equipped with:

- Indicators
- Tow mirrors

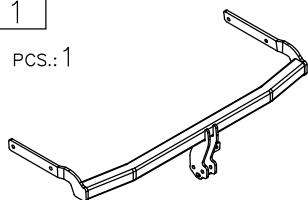
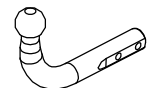
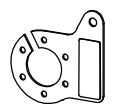
After 1000km of exploitation check all bolts and nuts. The ball of towbar must be always kept clear and conserve with a grease.

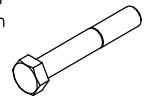
## Towbar accessories:

Pos. 1 Main bar PCS.: 1	Pos. 5 Bolt 8,8 B M10x40mm PCS.: 4	Pos. 10 Spring washer Ø12mm PCS.: 2
	Pos. 6 Washer Ø30xØ10,5x2,5mm PCS.: 4	Pos. 11 Spring washer Ø10mm PCS.: 4
Pos. 2 Tow ball pcs.: 1	Pos. 7 Nut 8 B M12 PCS.: 2	Pos. 12 Plain washer Ø8mm PCS.: 2
	Pos. 8 Plain washer Ø12mm PCS.: 2	Pos. 13 Nut 8 B M8 PCS.: 1
Pos. 3 Socket plate pcs.: 1		Pos. 14 Spring PCS.: 1
Pos. 4 Bolt 8,8 B M12x70mm PCS.: 2	Pos. 9 Bolt 8,8 B M8x45mm PCS.: 1	
		Pos. 15 Ball cover PCS.: 1
		



**PPUH AUTO-HAK Sp.J.**

Produkcja Zaczepów Kulowych  
Henryk & Zbigniew Nejman  
76-200 SŁUPSK ul. Słoneczna 16K  
tel/fax (059) 8-414-414; 8-414-413  
E-mail: office@autohak.com.pl  
www. autohak.com.pl

## Towing hitch (without electrical set)

Class: **A50-X** Cat. no. **G46**

Designed for:

Manufacturer: **RENAULT**

Model: **MEGANE**

Type: **ESTATE**

produced since 07.2003 till 2009

Technical data:

D-value: **7,74 kN**

maximum trailer weight: **1350 kg**

maximum vertical cup load: **75 kg**

Approval number acc. to regulations EKG/ONZ 55.01: **E20-55R-01 1340**

## Foreword

This towbar is designed according to rules of safety traffic regulations. The towing hitch is a safety component and can be install only by qualified personnel. Any alteration or conversion of the towing hitch is prohibited and would lead to cancellation of design certification. Remove insulating compound and underseal from vehicle (if present) in the area of the matting surfaces of the towing hitch.

The vehicle manufacturer's specifications regarding trailer load and max. vertical cup load are decisive for driving whereat values for the towing hitch cannot be exceeded.

*D-value formula:*

$$\frac{\text{Max trailer weight [kg]} \times \text{Max vehicle weight [kg]}}{\text{Max trailer weight [kg]} + \text{Max vehicle weight [kg]}} \times \frac{9,81}{1000} = D \text{ [kN]}$$